

Reddy

M100

Spec# 3114 G03

M100D

Spec# 3114 G15

Form # 2722-1
8-72

No.	Number	Part Name	M100	M100D
1	M13134-3D	Shell, Upper	1	1
2	M16781-4	Chamber, Combustion	1	1
	M11084-27*	Screw (Combustion Chamber attaching front)	2	2
	M11084-29*	Screw (Combustion Chamber attaching rear)	2	2
3	M15995	Plug, Button (Combustion Chamber rear head)	1	-
4	M16660	Bracket, Photocell	-	1
	M10908-1*	Screw (Photocell Bracket to Combustion Chamber rear head)	-	2
5	M16656-1	Cell and Bushing Assy	-	1
6	Ref.	Burner Head Assembly (See figure 14)	1	1
	M11084-27*	Screw (Burner Head to Combustion Chamber)	3	3
7	M16879	Air Line	1	1
7A	M12461-27	Screw, Slotted hex hd., No. 10-32 x 1/2 in.	-	1
7B	M24717	Clamp, Tube	-	1
7C	WLM-3	Lockwasher, No. 10	-	1
7D	NPF-3C	Nut, Plain No. 10-32	-	1
8	M15807	Strap, Retainer	1	1
	M11084-27*	Screw (Retainer Strap to Lower Shell)	2	2
9	M23147	Fan	1	1
10	SF4-2-1/2K	Set screw, Soc. Hd., cup pt., 1/4-20 (Fan to Motor Shaft)	2	2
11	Ref.	Motor Package Assembly (See figure 16)	1	1
12	M16661	Clamp, Motor	4	4
13	HC4-10C*	Screw (Motor Clamps)	2	2
14	WLM-4*	Lockwasher, 1/4 in. (Motor Clamps)	2	2
15	NPC-4C*	Nut, Hex, 1/4-20 (Motor Clamps)	2	2
16	M16777D	Shell, Lower	1	1
17	M11084-27*	Screw (Upper Shell to Lower Shell)	6	6
18	M11271-6*	Nut, Timmerman (Upper Shell to Lower Shell)	6	6
19	M12330A	Bracket, Shell Support	1	1
	M11084-27*	Screw (Support Bracket to Lower Shell and Fuel Tank)	4	4
	M11084-29*	Screw (Lower Shell to Support Bracket)	2	2

No.	Number	Part Name	M100	M100D
20	1000576	Grommet (Ignition cable thru Lower Shell)	2	3
21	M15809	Plug, Button (17/32 in. dia. hole)	1	-
22	M16646	Bracket, Motor Support	1	1
	M11084-27*	Screw (Motor Support Bracket to Lower Shell and Fuel Tank)	6	6
23	1000576	Grommet (Motor Leads thru Motor Support Brkt.)	1	1
24	M16697	Transformer, 5000 Volt	1	1
	M11084-27	Screw (Transformer to Motor Support Bracket)	2	2
25	M11954	Bushing, Strain Relief (Service Cord to Lower Shell)	1	1
26	M10813-33	Cord Assembly, Extension	1	-
26	M10813-34	Cord Assembly, Extension	-	1
27	M18360-4C	Tank Assembly, Fuel	1	1
28	M23284	Cap, Fuel Tank	1	1
29	M16053	Screen, Filler neck	1	1
30	M10990-3	Bushing, Rubber (Fuel Filter into Fuel Tank)	1	1
31	M21040	Plug, Pipe, Hex hd, 1/4-18	1	-
	M24973	Plug, Drain	-	1
32	M11952	Bracket, Starting Relay Mtg.	1	-
33	M12462-9	Relay, Starting	1	-
	RC2-2C*	Screw (Starting Relay to Mounting Bracket)	2	-
	WLI-2	Lockwasher, Internal No. 8	2	-
	ST2-2AC	Screw (Grounding)	1	1
	M11084-27	Screw (Relay Bracket to Shell)	1	1
	M16852-5	Relay Bracket Assembly	-	NA
34	M12462-9	Relay	-	1
35	RC2-2C*	Screw (Relay to Relay Brkt)	-	2
36	M14378-2	Relay Assembly	-	1
37	M12461-2*	Screw (Relay to Relay Brkt)	-	1
38	M14360	Breaker, Circuit	-	1
39	M16851-1	Bracket Assembly, Control	-	1
	M9900-62	Wire Assembly, Black (To Starting Relay)	1	1
	M9900-80	Wire Assy (To Breaker)	-	1
	M16615-1	Harness, Shell	-	1
	M13942-2	Connector (Cell and Bushing and Relay to Circuit Breaker)	-	3
	M13942-4	Connector (Relay Leads)	2	2

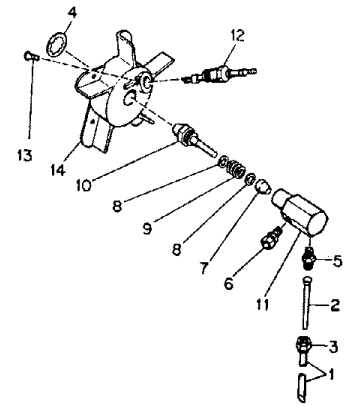

1	M16790-2	Filter Tube (M100)	1	1
	M16790-8	Filter, Tube (M100D)	1	1
2	M19630	Filter, Fuel	1	1
3	M13849	Nut, Flared	1	1
4	M16741-18	Ring, Retaining	1	1
	M23151-1	Nozzle Adapter Assy	1	1
5	M16781	Connector, Male	1	1
6	M5976	Connector, Male	1	1
7	M8882	Sleeve, Nozzle Seal	1	1
8	M10659-1	Washer, Nozzle Seal	2	2
9	M10809-1	Spring, Nozzle Seal	1	1
10	M23103	Nozzle, Aspiring 0.66 GPH	1	1
11	M16535	Adapter, Nozzle	1	1
12	M16895-1	Spark Plug Assy	1	1
13	M12461-51	Screw	1	1
14	M16534	Body, Burner Head	1	1

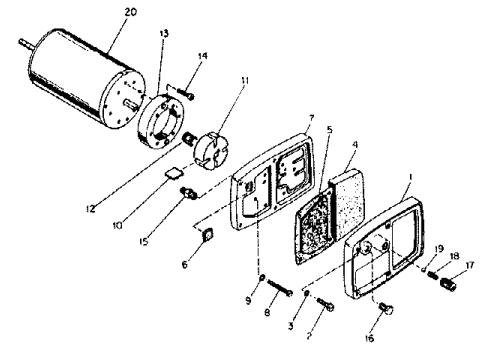

1	M16545	End Cover, Filter	1	1
2	M12461-31*	Screw (Filter End Cover to Pump End cover)	4	4
3	WLI-3	Lockwasher, Internal No. 10	4	4
4	M12179	Intake Air Filter	1	1
5	M12244-1	Output Filter Assy.	1	1
6	M11637	Filter, Lint	1	1
7	M12233	Front Cover, Pump (Port Plate)	1	1
8	M12461-32*	Screw (End Cover to Motor)	6	6
9	WLI-3	Lockwasher, Internal No. 10	6	6
10	M8643	Blade	4	4
11	M22456-1	Rotor	1	1
12	M22009	Insert	1	1
13	M8645	Pump Body	1	1
14	FHPF3-4C	Screw (Pump Body to Motor)	2	2
15	M5976	Connector, Male	1	1
16	M22997	Plug	1	1
17	M23105	Screw, Pressure Adjustment	1	1
18	M10993-1	Spring, Compression (Pressure Relief)	1	1
19	M8940	Ball 1/4 in. dia.	1	1
20	M23107-1	Motor	1	1

